

1 UNIT 8 KITCHEN
1 : 50 on A1 / 1 : 100 on A3

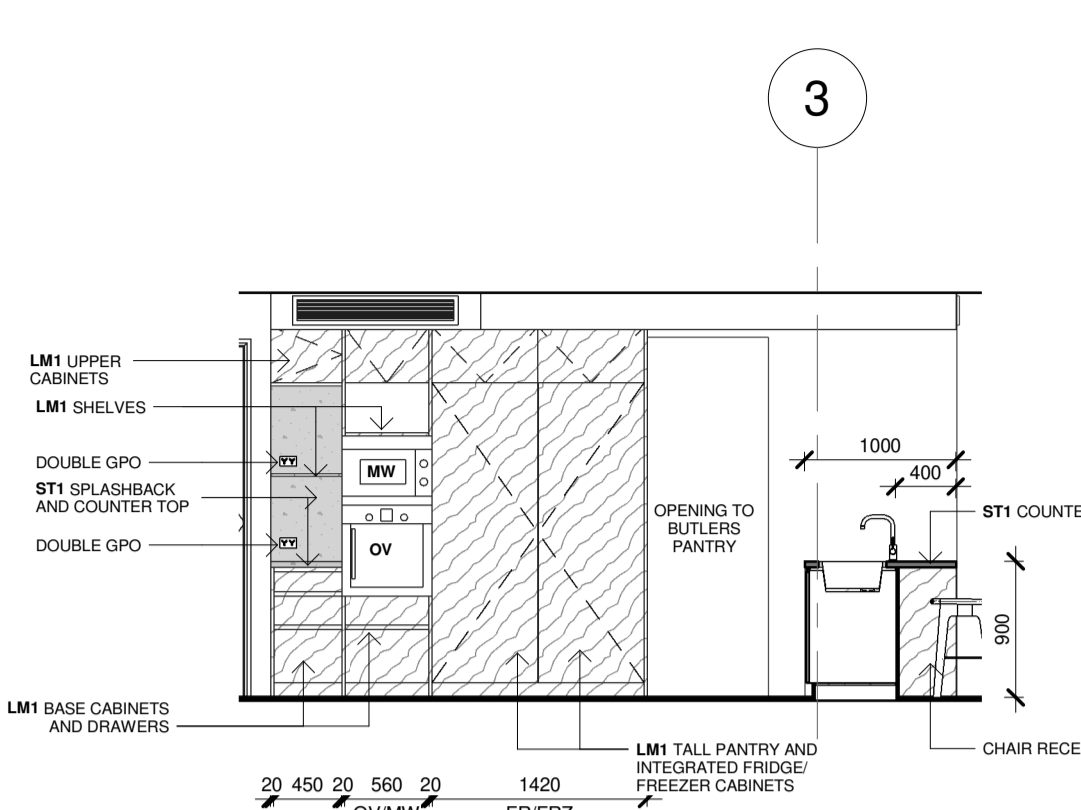

8.25 ELEVATION
1 : 50

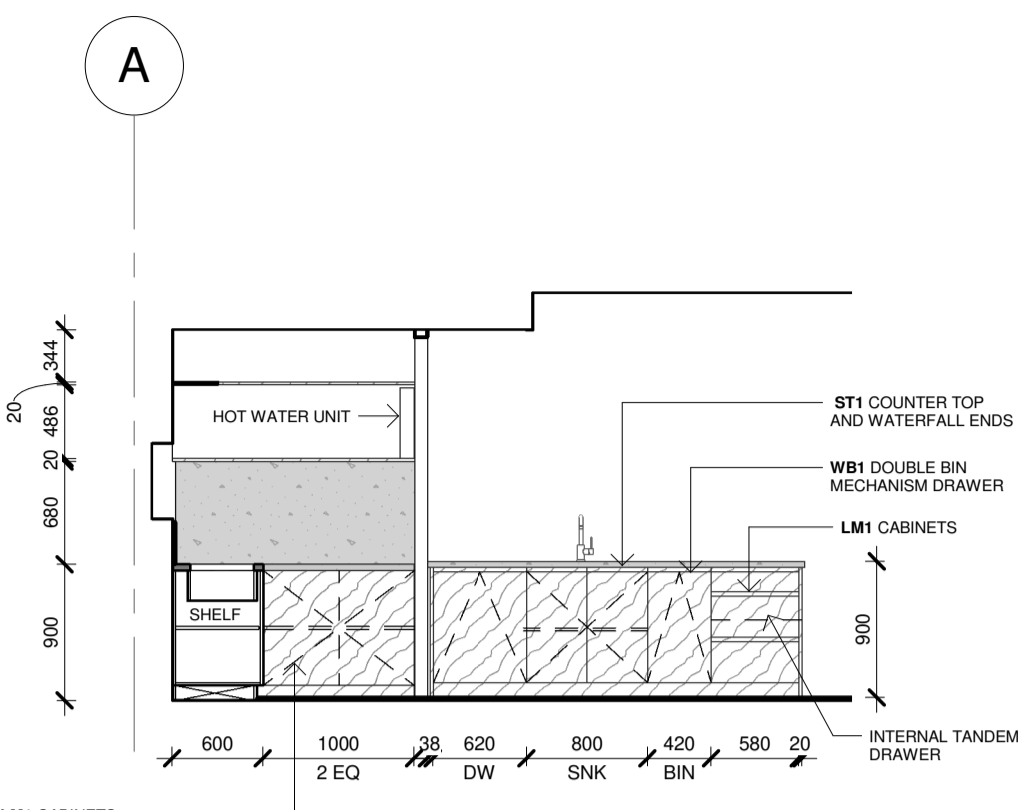

8.26 ELEVATION
1 : 50

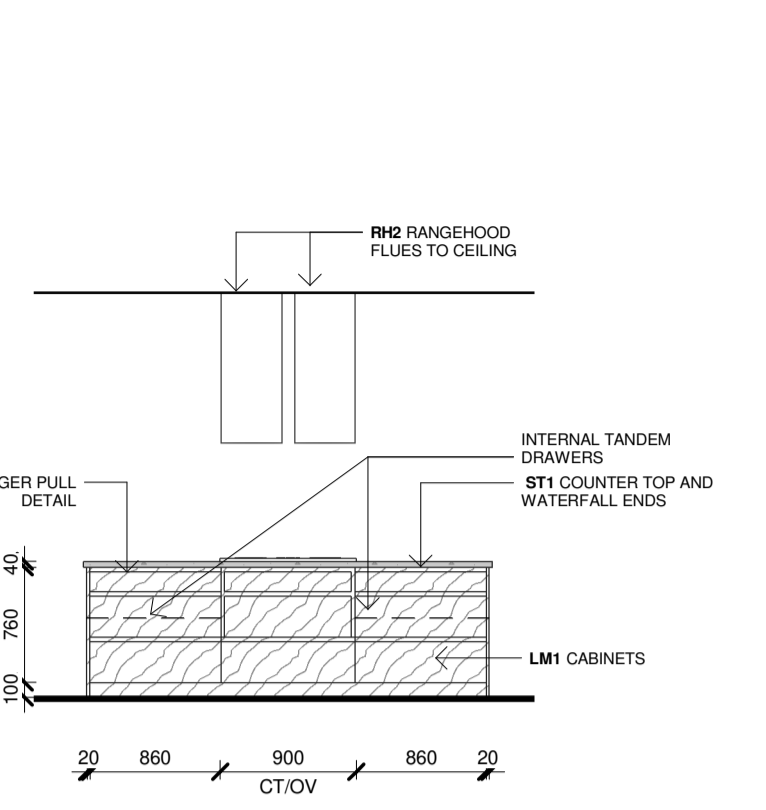

8.27 ELEVATION
1 : 50

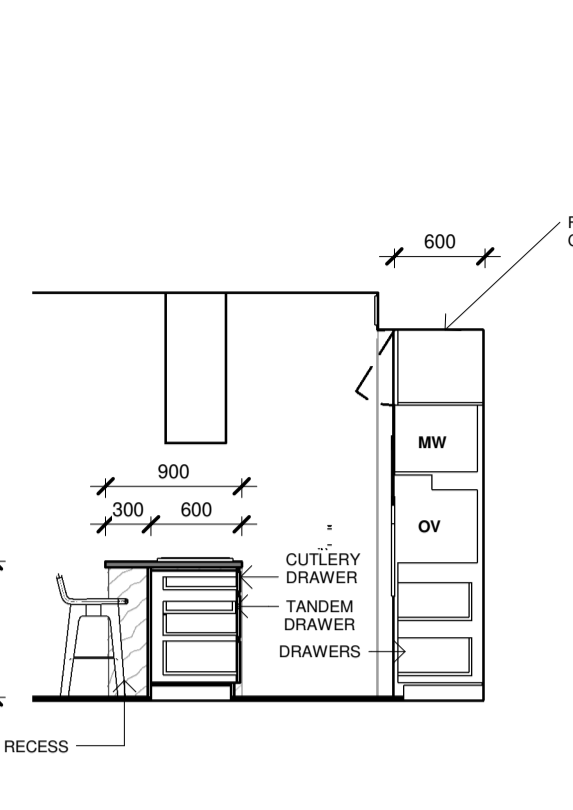

8.28 ELEVATION
1 : 50

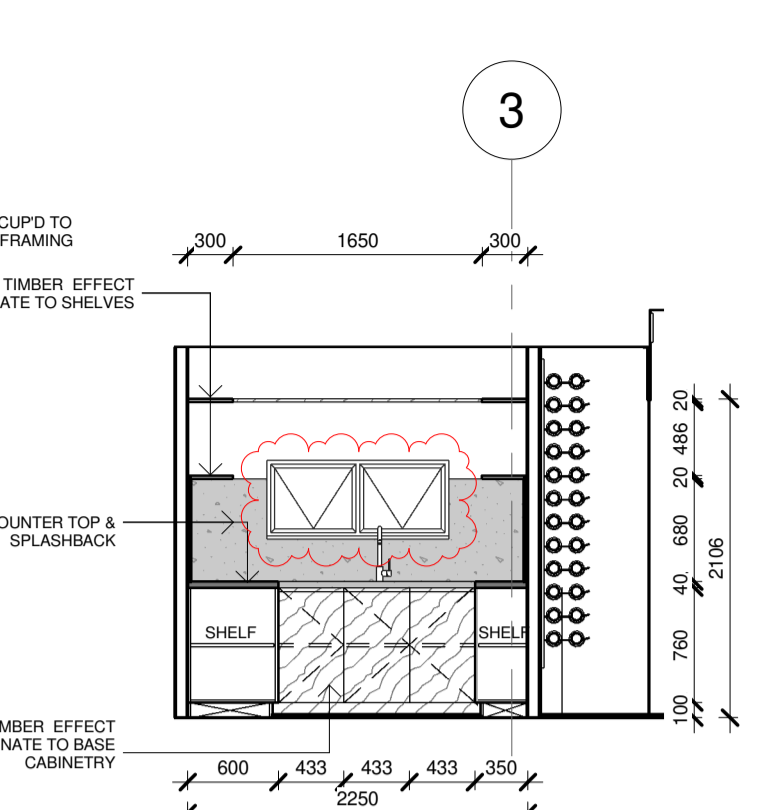

8.29 ELEVATION
1 : 50

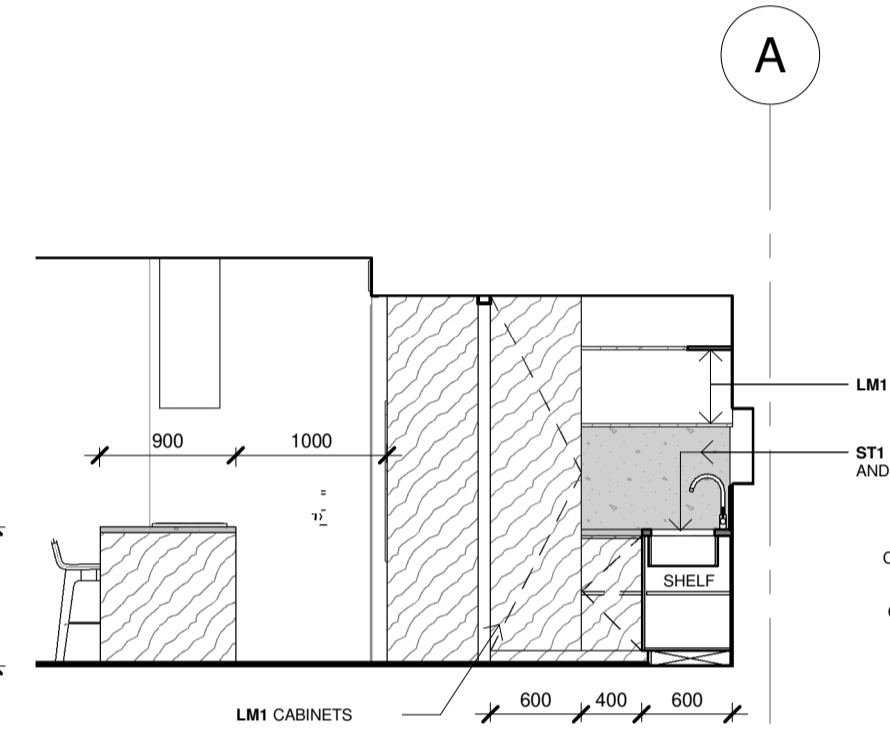

8.30 ELEVATION
1 : 50

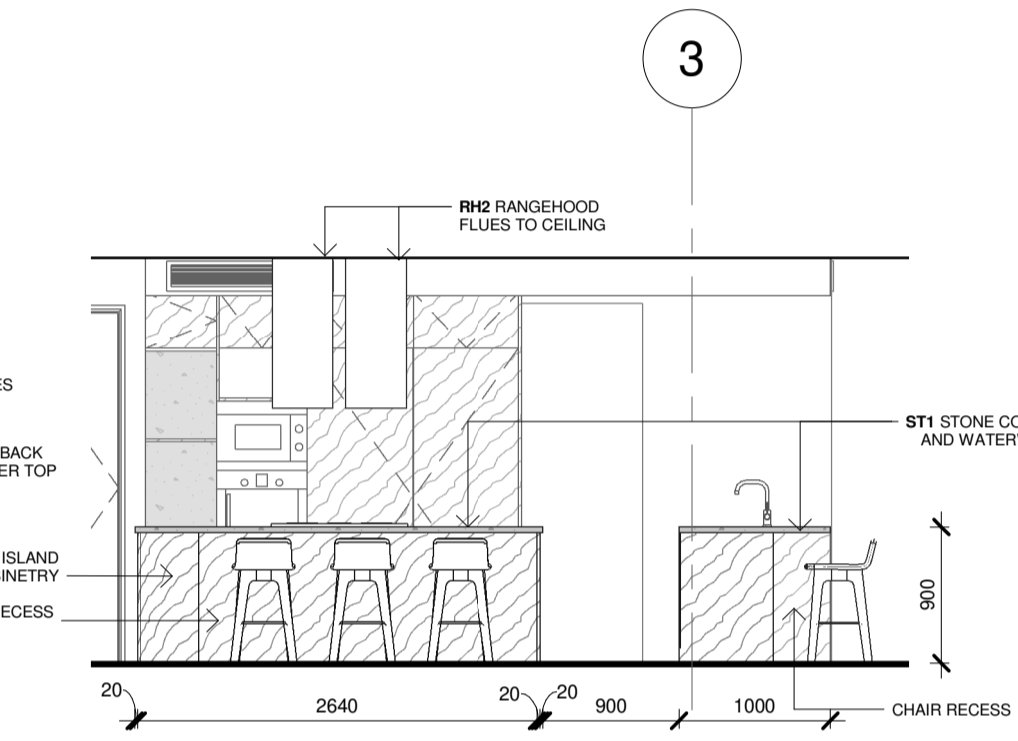

8.31 ELEVATION
1 : 50

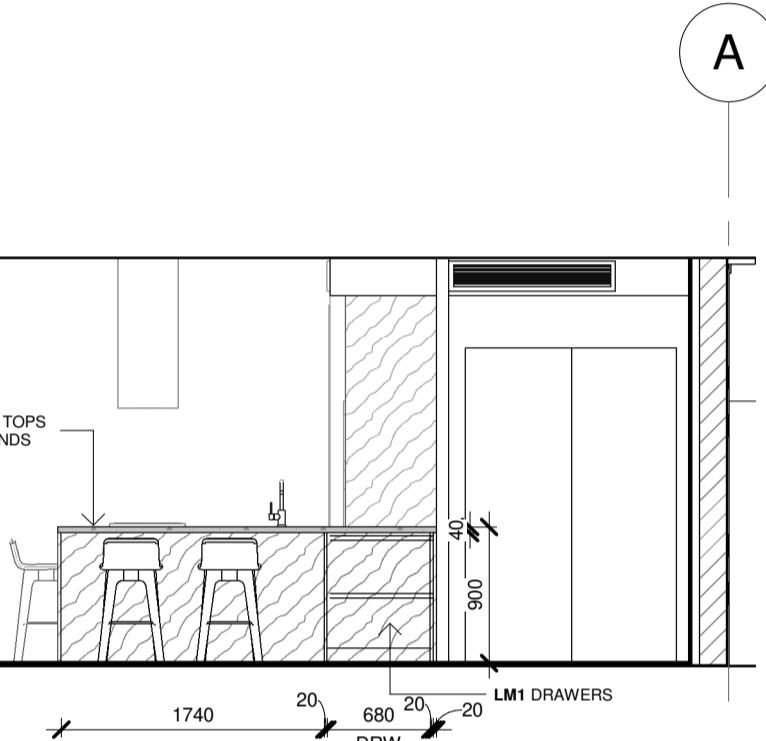

8.32 ELEVATION
1 : 50

APPLIANCES LEGEND	
REFER TO FINISHES SCHEDULE FOR FULL SPEC INFO	
OV	OVEN - 600W (800W UNIT 8 ONLY)
MW	MICROWAVE - 600W
WD	WARMING DRAWER - 600W (UNIT 8 ONLY)
CT	COOKTOP - 800W (800W UNIT 8 ONLY)
UBFR	UNDERBENCH FRIDGE
DW	DIWASHER
RH	UNDER CUPBOARD RANGEHOOD 900W
RH2	ISLAND HOODS (UNIT 8 ONLY)
FR	INTERGRATED FRIDGE
FRZ	INTERGRATED FREEZER
WB1	INTERGRATED WASTE BIN WITH LID

CABINETRY FINISHES LEGEND	
REFER TO FINISHES SCHEDULE FOR FULL SPEC INFO	
LM1	LAMINATE - TIMBER LOOK
LM2	COMPACT LAMINATE - SOLID CORE
LM3	LAMINEX DEMI ROUND 2PAC - WHITE
ST1	STONE SLAB 20mm THICK
WT2	MOSAIC FINGER TILE
PT1	PAINT FINISH - LOW SHEEN
CG1	CLEAR GLAZING WINE CABINET
PF1	PATCH FITTINGS - WALL MOUNTED
PF2	PATCH FITTINGS - 135 DEGREE DOOR HINGE
HD2	PATCH FIXED GLASS DOOR PULL
HG1	CABINETRY HINGES
DG1	DRAWER GLIDES

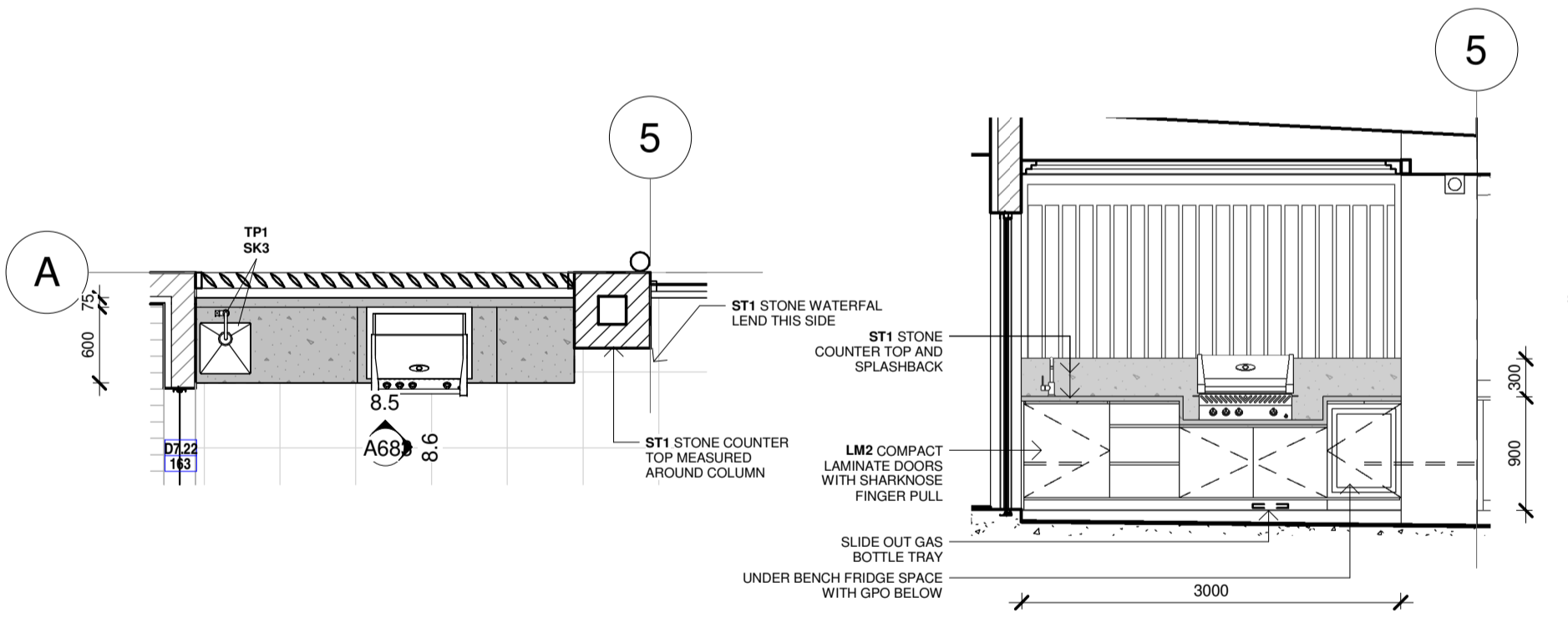

8.5 ELEVATION
1 : 50

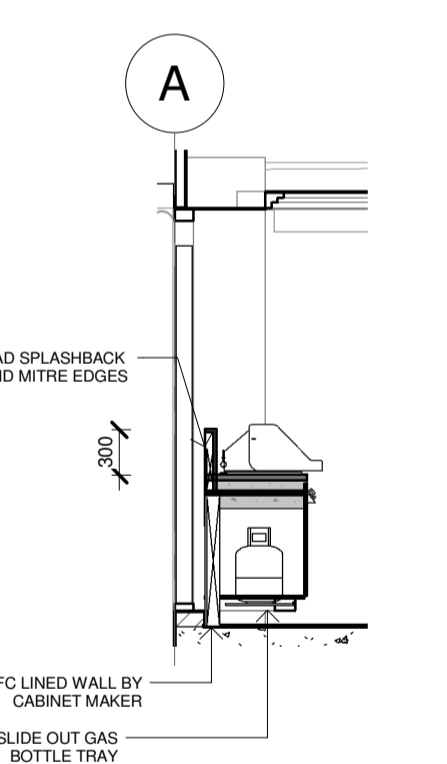

8.6 ELEVATION
1 : 50

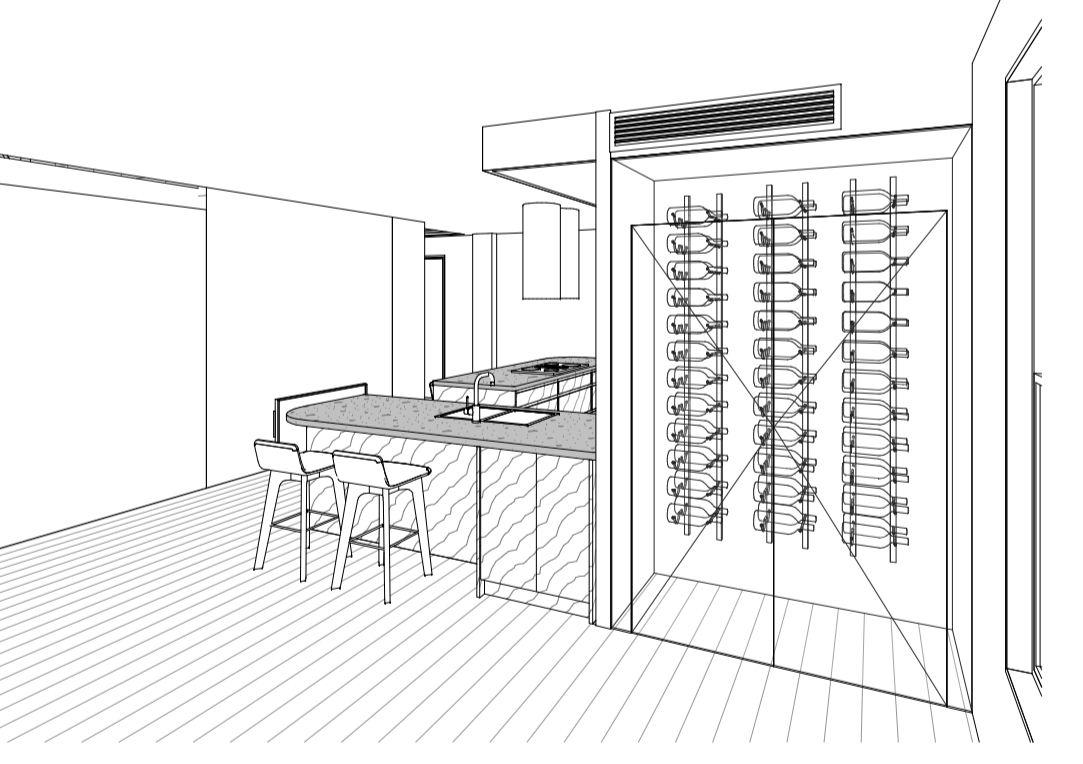
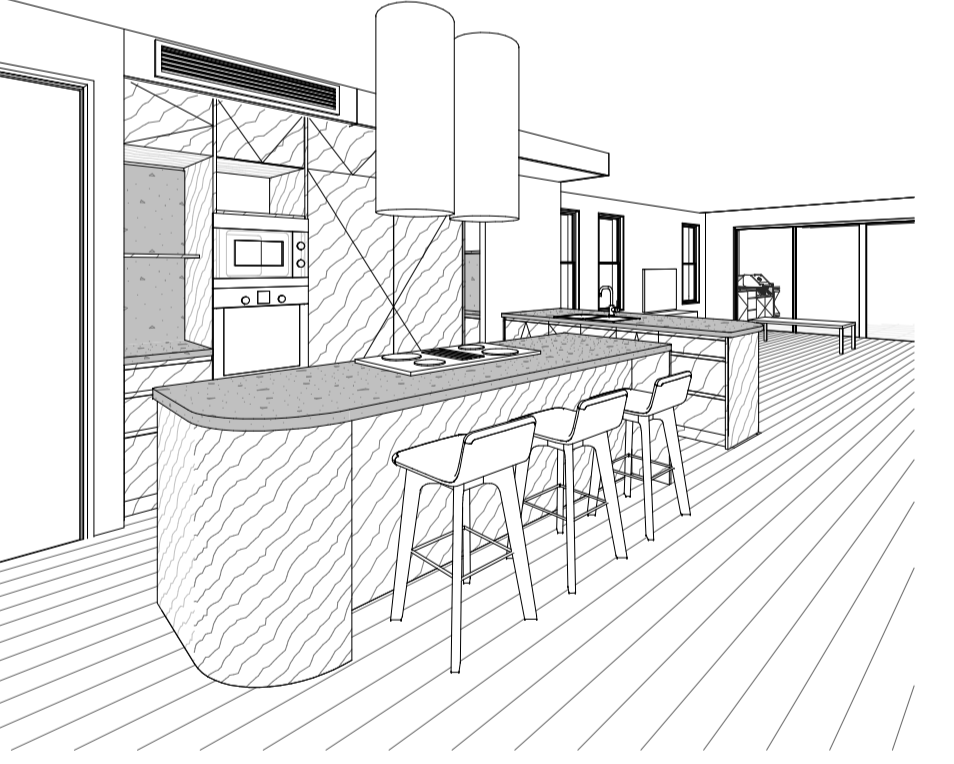

2 UNIT 8 BBQ
1 : 50 on A1 / 1 : 100 on A3

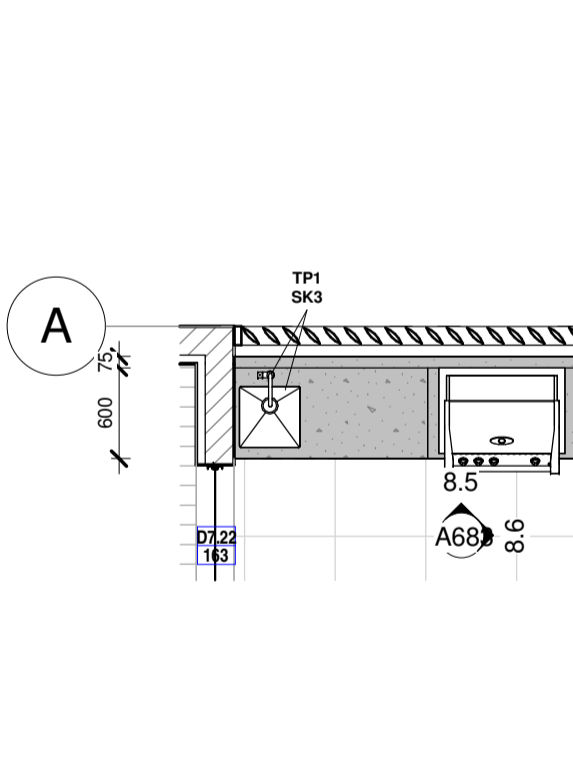

8.5 ELEVATION
1 : 50

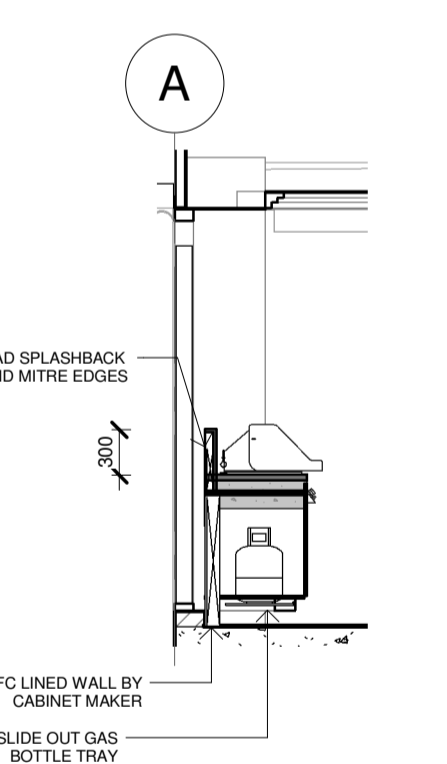

8.6 ELEVATION
1 : 50

#	DESCRIPTION	DATE
B	UNIT 8 PANTRY WINDOW	11.03.2026
A	FOR CONSTRUCTION	10.09.2025
6	VALUE MANAGEMENT	04.03.2025
5	IBA COORDINATION	15.01.2025
4	SCHEDULE CODES & UNIT 8 KITCHEN	05.11.2024
3	TENDER 2	17.09.2024
2	CABINETS	03.09.2024
1	TENDER-1	17.11.2023

REVISION HISTORY		
FOR CONSTRUCTION		
ACN: 110893493 US-Level 1 - 70 Bay Terrace, WYNNUM QLD 4178 P.O. BOX 5129 MANLY QLD 4179 email: enquiries@thinktankarchitects.com.au phone: (07)3348 3727 / mobile: 0412 087 196		
These drawings are the copyright of THINK TANK Architects and are not to be reproduced in any way without the consent of THINK TANK Architects		
PROJECT	13-22	
NEW RESIDENCES		
ADDRESS 121 SHORE ST N, CLEVELAND		
CLIENT BLANCA		
ARCHITECT MICHAEL JULLYAN		
DRAWN	CHECKED	
KP/ZS	MJ	
ISSUE CONSTRUCTION		
SHEET TITLE UNIT 8 KITCHEN		
SHEET NUMBER	REV	REV DATE
A683	B	11.03.2026



CURRENT: 2024/10/22, 21 Shore St N, Cleveland, QLD 4169